

**Modular Cooking Range Line
 thermaline 85 - 4 Zone Full Surface
 Induction Top on Open Base, 1 Side,
 Backsplash (H2)**

ITEM # _____

MODEL # _____

NAME # _____

SIS # _____

AIA # _____

588734
 (Mbjdgbj1aa)

 Free-zone Induction on open base
 (34x74x33h cm), H2, 4 zones, 1-side
 operated with backsplash

Short Form Specification

Item No. _____

Unit constructed according to DIN 18860_2 with 20 mm drop nose top and 70 mm recessed plinth. Internal frame for heavy duty sturdiness in stainless steel. 2 mm top in 1.4301 (AISI 304). Flat surface construction, easily cleanable. THERMODUL connection system enables seamless worktop when units are connected and avoids soil penetrating. Free zone multi-coil glass ceramic surface without dead spots can host up to 16 pots&pans. Minimum cookware diameter is 7 mm. UI design to control each coil independently, power (W) and temperature settings are possible. Overheat protection switches off the supply in case of overheating. IPX5 water resistance certification. Configuration: Freestanding, one-side operated, on open base, with backsplash, hygienic class H2.

Main Features

- The free zone induction offers the possibility to use multiple pots and pans, even small sizes (min diameter 7 cm), thanks to the multi-coil system design that makes all the surface active, ideal for à la carte menu.
- The smooth glass-ceramic surface features limited temperature increase and it can be quickly and easily cleaned, thus providing maximum hygiene.
- THERMODUL connection system creates a seamless work top when units are connected to each other thus avoiding soil penetrating vital components and facilitating the removal of units in case of replacement or service.
- 360° round stepless metal knobs, working clock and anticlock wise for quick parameters selection and adjustment.
- Each zone is controlled by a touch-sensitive keypad with 7 touch buttons, 4 displays and a round knob. Each zone consists in 4 coils, which can be individually controlled or bridged in 2, 3 or 4. Power (watts) or temperature (°C) can be selected. A function is also available to set and save 3 different configurations.
- Power setting from 25 to 2000 watt in 30 steps or temperature settings from 30 to 250° C in steps of 1°C.
- Electronic sensor, placed underneath the glass, below the coil center position, to precisely measure the temperature of the pan/pot bottom
- Overheat protection: the temperature sensor switches off the supply in case of overheating.
- Heating system automatically switches off when pots and pans are removed.
- Low heat dissipation to the kitchen.

Construction

- Unit constructed according to DIN 18860_2 with 20 mm drop nose top and 70 mm recessed plinth.
- Flat surface construction with minimal hidden areas to easily clean all surfaces
- Internal frame for heavy duty sturdiness in stainless steel.
- All major components may be easily accessed from the front, including the induction filters.
- 2 mm top in 1.4301 (AISI 304).
- 34x74x33 cm (wxdxh) open base with round corners H2 for storage.
- IPX5 water resistance certification.

Sustainability



- This model is compliant with Swiss Energy Efficiency Ordinance (730.02).

Optional Accessories

- Scraper for cook tops PNC 910601
- Connecting rail kit for appliances with backsplash, 850mm PNC 912498
- Portioning shelf, 1000mm width PNC 912528
- Portioning shelf, 1000mm width PNC 912558

APPROVAL: _____

• Folding shelf, 300x850mm	PNC 912579	<input type="checkbox"/>	• C41 HI-TEMP RAPID DEGREASER, 1 pack of six 1 lt. bottles (trigger incl.)	PNC 0S2292	<input type="checkbox"/>
• Folding shelf, 400x850mm	PNC 912580	<input type="checkbox"/>	• S01 STAINLESS STEEL SURFACE POLISHER; 6 BOTTLES X 750ML C/T	PNC 0S2881	<input type="checkbox"/>
• Fixed side shelf, 200x850mm	PNC 912586	<input type="checkbox"/>	• S02 Degreaser for ovens and SpeedDelight. Specific for cleaning the cooking chambers of GourmeXpress and SpeeDelight. Active up to a maximum of 50°C Complete with spray bottle Pack of 6 750ml bottles	PNC 0S2882	<input type="checkbox"/>
• Fixed side shelf, 300x850mm	PNC 912587	<input type="checkbox"/>	• S03 ALCOHOL BASE DETERGENT; 6 BOTTLES X 750ML; ADR&IMDG&IATA Limited Quantity	PNC 0S2883	<input type="checkbox"/>
• Fixed side shelf, 400x850mm	PNC 912588	<input type="checkbox"/>	• S04 GLASSES & HARD SURFACES CLEANERS; 6 BOTTLES X 750ML	PNC 0S2884	<input type="checkbox"/>
• Stainless steel front kicking strip, 1000mm width	PNC 912636	<input type="checkbox"/>	• S05 - MULTIPURPOSE DEGREASER; 6PCS X 750ML; ADR&IMDG Limited Quantity	PNC 0S3257	<input type="checkbox"/>
• Stainless steel side kicking strip left and right, wall mounted, 850mm width	PNC 912659	<input type="checkbox"/>			
• Stainless steel side kicking strip left and right, back-to-back, 1700mm width	PNC 912662	<input type="checkbox"/>			
• Stainless steel plinth, against wall, 1000mm width	PNC 912884	<input type="checkbox"/>			
• Stainless steel side panel, 850x700mm, right side, against wall	PNC 913003	<input type="checkbox"/>			
• Stainless steel side panel, 850x700mm, left side, against wall	PNC 913004	<input type="checkbox"/>			
• Back panel, 1000x700mm, for units with backsplash	PNC 913015	<input type="checkbox"/>			
• Endrail kit, flush-fitting, with backsplash, left	PNC 913115	<input type="checkbox"/>			
• Endrail kit, flush-fitting, with backsplash, right	PNC 913116	<input type="checkbox"/>			
• Endrail kit (12.5mm) for thermaline 85 units with backsplash, left	PNC 913206	<input type="checkbox"/>			
• Endrail kit (12.5mm) for thermaline 85 units with backsplash, right	PNC 913207	<input type="checkbox"/>			
• U-clamping rail for back-to-back installations with backsplash (to be ordered as S-code)	PNC 913226	<input type="checkbox"/>			
• Insert profile, d=850mm	PNC 913231	<input type="checkbox"/>			
• Perforated shelf for warming cabinets and cupboard bases (one-side operated TL80-85-90 and two-side operated for TL80)	PNC 913233	<input type="checkbox"/>			
• Side reinforced panel only in combination with side shelf, for against the wall installations, right	PNC 913261	<input type="checkbox"/>			
• Side reinforced panel only in combination with side shelf, for against the wall installations, left	PNC 913262	<input type="checkbox"/>			
• Shelf fixation for TL80-85-90 one-side operated, TL80 two-side operated	PNC 913279	<input type="checkbox"/>			
• Stainless steel dividing panel, 850x700mm, (it should only be used between Electrolux Professional thermaline Modular 85 and thermaline C85)	PNC 913670	<input type="checkbox"/>			
• Stainless steel side panel, 850x700mm, flush-fitting (it should only be used against the wall, against a niche and in between Electrolux Professional thermaline and ProThermetic appliances and external appliances - provided that these have at least the same dimensions)	PNC 913686	<input type="checkbox"/>			
• Peak management system for Free-zone Induction, half module (8 coils)	PNC 921026	<input type="checkbox"/>			

Recommended Detergents



Front

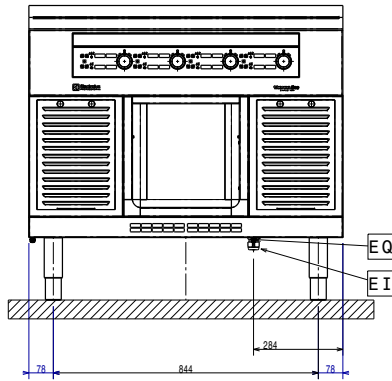

Side

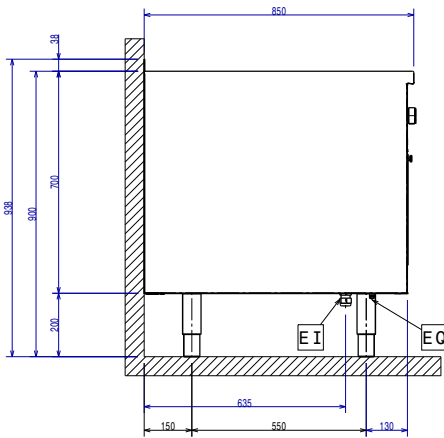

EI = Electrical inlet (power)
 EQ = Equipotential screw

Top

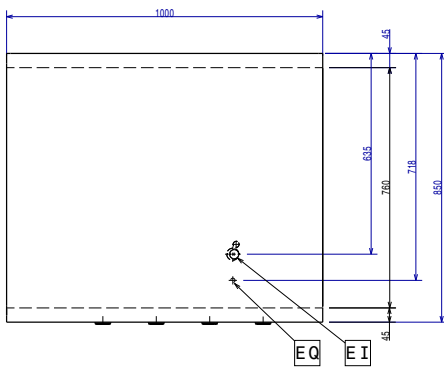
Electric

Supply voltage: 400 V/3N ph/50/60 Hz
 Total Watts: 32 kW

Key Information:

External dimensions, Width: 1000 mm
 External dimensions, Depth: 850 mm
 External dimensions, Height: 700 mm
 Storage Cavity Dimensions (width): 340 mm
 Storage Cavity Dimensions (height): 330 mm
 Storage Cavity Dimensions (depth): 738.5 mm
 Net weight: 118 kg

Configuration: On Base; One-Side Operated
 Front Plates Power: 8 - 8 kW
 Back Plates Power: 8 - 8 kW
 Front Plates dimensions: 320x320 320x320
 Back Plates dimensions: 320x320 320x320

Sustainability

Current consumption: 43 Amps

Optional Accessories

- Scraper for cook tops PNC 910601
- Connecting rail kit for appliances with backsplash, 850mm PNC 912498
- Portioning shelf, 1000mm width PNC 912528
- Portioning shelf, 1000mm width PNC 912558
- Folding shelf, 300x850mm PNC 912579
- Folding shelf, 400x850mm PNC 912580
- Fixed side shelf, 200x850mm PNC 912586
- Fixed side shelf, 300x850mm PNC 912587
- Fixed side shelf, 400x850mm PNC 912588
- Stainless steel front kicking strip, 1000mm width PNC 912636
- Stainless steel side kicking strip left and right, wall mounted, 850mm width PNC 912659
- Stainless steel side kicking strip left and right, back-to-back, 1700mm width PNC 912662
- Stainless steel plinth, against wall, 1000mm width PNC 912884
- Stainless steel side panel, 850x700mm, right side, against wall PNC 913003
- Stainless steel side panel, 850x700mm, left side, against wall PNC 913004
- Back panel, 1000x700mm, for units with backsplash PNC 913015
- Endrail kit, flush-fitting, with backsplash, left PNC 913115
- Endrail kit, flush-fitting, with backsplash, right PNC 913116
- Endrail kit (12.5mm) for thermaline 85 units with backsplash, left PNC 913206
- Endrail kit (12.5mm) for thermaline 85 units with backsplash, right PNC 913207
- U-clamping rail for back-to-back installations with backsplash (to be ordered as S-code) PNC 913226
- Insert profile, d=850mm PNC 913231
- Perforated shelf for warming cabinets and cupboard bases (one-side operated TL80-85-90 and two-side operated for TL80) PNC 913233
- Side reinforced panel only in combination with side shelf, for against the wall installations, right PNC 913261
- Side reinforced panel only in combination with side shelf, for against the wall installations, left PNC 913262
- Shelf fixation for TL80-85-90 one-side operated, TL80 two-side operated PNC 913279

- Stainless steel dividing panel, 850x700mm, (it should only be used between Electrolux Professional thermaline Modular 85 and thermaline C85) PNC 913670
- Stainless steel side panel, 850x700mm, flush-fitting (it should only be used against the wall, against a niche and in between Electrolux Professional thermaline and ProThermetic appliances and external appliances - provided that these have at least the same dimensions) PNC 913686
- Peak management system for Free-zone Induction, half module (8 coils) PNC 921026

Recommended Detergents

- C41 HI-TEMP RAPID DEGREASER, 1 pack of six 1 lt. bottles (trigger incl.) PNC 0S2292
- S01 STAINLESS STEEL SURFACE POLISHER; 6 BOTTLES X 750ML C/T PNC 0S2881
- S02 Degreaser for ovens and SpeedDelight. Specific for cleaning the cooking chambers of GourmeXpress and SpeeDelight. Active up to a maximum of 50°C Complete with spray bottle Pack of 6 750ml bottles PNC 0S2882
- S03 ALCOHOL BASE DETERGENT; 6 BOTTLES X 750ML; ADR&IMDG&IATA Limited Quantity PNC 0S2883
- S04 GLASSES & HARD SURFACES CLEANERS; 6 BOTTLES X 750ML PNC 0S2884
- S05 - MULTIPURPOSE DEGREASER; 6PCS X 750ML; ADR&IMDG Limited Quantity PNC 0S3257